



-

:

-

-3535 C

F :

-
-
-
-

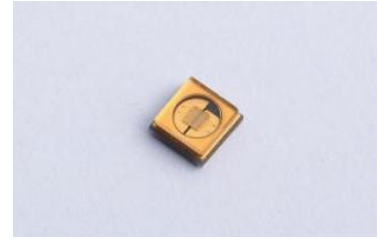

A :

:

| (25 C) | | | |
|--------|--|--|--|
| | | | |
| | | | |
| | | | |
| | | | |
| (25 C) | | | |
| | | | |
| | | | |
| | | | |
| | | | |

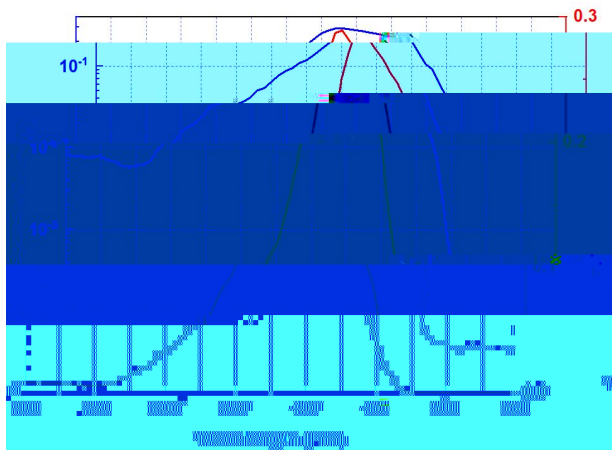

27.045

27.045



A :

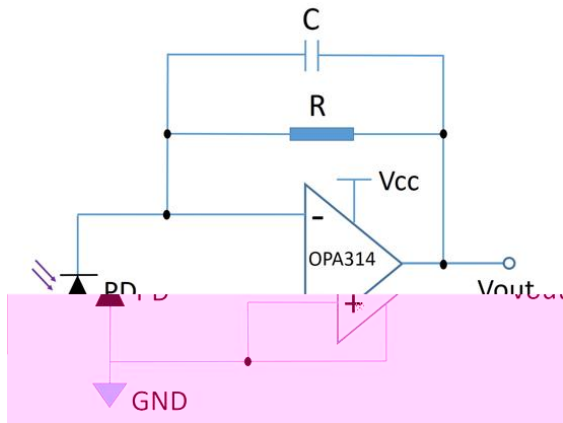

$$V_{out} (V) = I_{ph} (A) \times R (\Omega)$$

$$I_{ph} (A) = R_{\lambda} (A/W) \times A (cm^2) \times P (W/cm^2)$$

where A is chip area, Φ is UV power density and R_{λ} is responsivity at specific wavelength.

E :

