



UVC photodiode

Model **GT-UVC-L**

General Features:

- Selective response to UVC band
- Photovoltaic mode operation
- TO-46 metal housing
- Good solar blindness
- High responsivity and low dark current



Applications: UV sterilizing lamp monitoring, UV radiation dose measurement, flame detection

Specifications:

Parameters	Symbol	Value	Unit
Maximum ratings			
Operation temperature range	T_{opt}	-25-85	°C
Storage temperature range	T_{sto}	-40-80	°C
Soldering temperature (3 s)	T_{sol}	260	°C
Reverse voltage	V_{r-max}	-10	V
General characteristics (25 °C)			
Chip size	A	1	mm ²
Dark current ($V_r = -1$ V)	I_d	<1	nA
Temperature coefficient (@265 nm)	T_c	0.05	%/°C
Capacitance (at 0 V and 1 MHz)	C_p	18	pF
Spectral response characteristics (25 °C)			
Wavelength of peak responsivity	ρ	285	nm
Peak responsivity (at 285 nm)	R_{max}	0.178	A/W
Spectral response range ($R=0.1 \times R_{max}$)	-	225-290	nm
UV-visible rejection ratio ($R_{max}/R_{400\text{ nm}}$)	-	$>10^4$	-

Spectral response

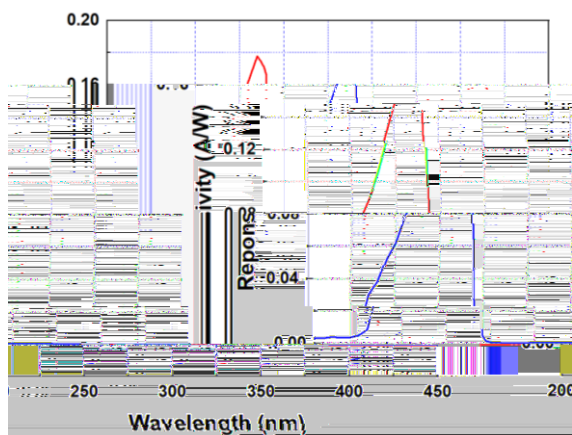

Package dimensions

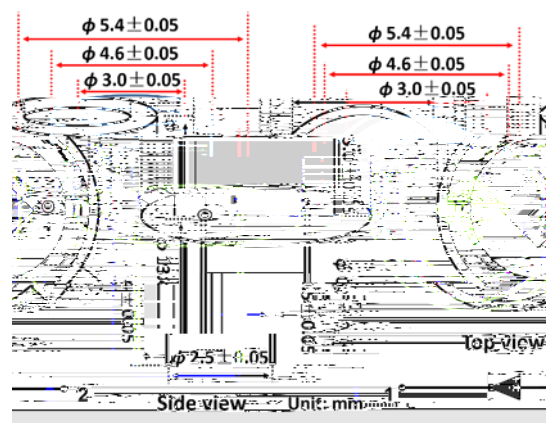



UVC photodiode

Model GT-UVC-L

Application circuit:

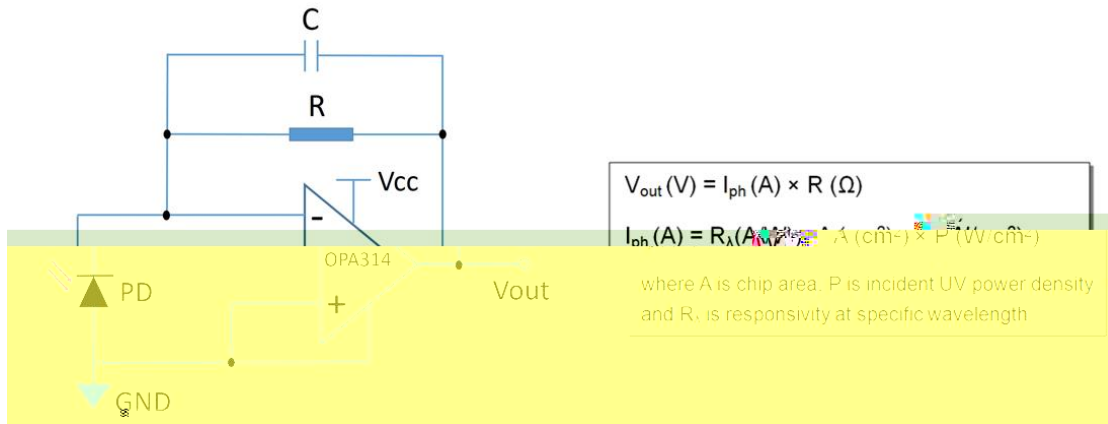

Evaluation circuit board:

A

